



**TRAERGER**<sup>®</sup>  
**OWNER'S MANUAL**  
**BBQ070**



**RESIDENTIAL PELLET GRILL**

This Grill Protected Under Patent Number: 4,823,684

**FOR OUTDOOR USE ONLY!**

**WARNING!**

**DO NOT STORE OR USE NEAR GASOLINE OR OTHER  
FLAMMABLE OR COMBUSTABLE LIQUIDS IN THE  
VICINITY OF THIS APPLIANCE! USE ONLY TRAEGER  
BRAND BBQ PELLETS IN THE OPERATION OF THIS  
UNIT.**

# INTRODUCTION

**Congratulations on your purchase of this TRAEGER WOOD PELLET GRILL, Model 070 Lil' Tex.** With proper set-up, operation and maintenance, this grill will provide you with years of cooking enjoyment.

Your new grill comes almost completely assembled. You will need to complete the assembly which includes:

- 1) Mounting the side box (23) onto the main barbecue body (2)
- 2) Mounting the smoke stack (1) onto the main barbecue body (2)
- 3) Positioning the U-shaped firepot cover (5) over the firepot (10), and setting the angled drip pan (6) in place.
- 4) Attach
- 5) Attach the rear wheels to the barbecue body (27)
- 6) Hanging the grease bucket (22) on the grease drain tube hook (16) located on the grease drain tube.

***NOTE : NUMERALS FOLLOWING PART NAMES THROUGHOUT THIS MANUAL REFER TO THE COMPONENT DIAGRAM ON THE PREVIOUS PAGE.***

When you un-box your grill, make sure you have, and can identify all of the following parts:

- (1) Bag of nuts, washers, and bolts. These are for mounting the pellet hopper/firepot, smokestack and handle to the barbecue.
- (1) Main barbecue body (2)
- (1) Pellet hopper/firepot (23)
- (2) Viper Casters (29)
- (2) Wheels (27)
- (1) Porcelain coated cooking grill (4). Remove for assembly
- (1) U-shaped firepot cover (5). Remove from grill for assembly
- (1) Angled drip pan (6). Remove from grill for assembly
- (1) Grease catch bucket (22)
- (1) Smokestack (1)

Follow these step by step instructions and you'll be cookin' in no time!

## TOOLS REQUIRED FOR ASSEMBLY

- 7/16" open-end wrench or an adjustable crescent wrench.
- A Phillips screwdriver or screw gun with a Phillips screw driver bit
- 1/4" Allen wrench

# SECTION ONE: ASSEMBLY INSTRUCTIONS

## ***MOUNTING THE PELLETT HOPPER/FIREPOT:***

- 1) Slide the side box (23) square tube into the square opening located on the left side of the main barbecue body (2). Gently push the firepot into the body until the pellet hopper is snug against the main barbecue body (2).
- 2) Align the bolt holes (21) on the side box with the bolt holes on the barbecue body (2).
- 3) Insert the four ¼ inch bolts (21) from the inside main barbecue body into the nut zerts (24) found on the right side of the pellet hopper/firepot box. Place a washer over each bolt and screw into the nut zert (24). Use a socket wrench to tighten bolts. **DO NOT OVER TIGHTEN BOLTS.**

## ***INSTALLING THE SMOKE STACK:***

Attach the smokestack (1) onto the right hand end of the main barbecue body using the bolts, washers and nuts supplied. Washers should be placed between the bolt head and barbecue body on the outside. A washer should also be placed on the bolt inside the barbecue body prior to threading the nut onto the bolt.

## ***INSTALLING THE WHEELS:***

Install wheels as shown in diagram.  
Do not over tighten the bolt.

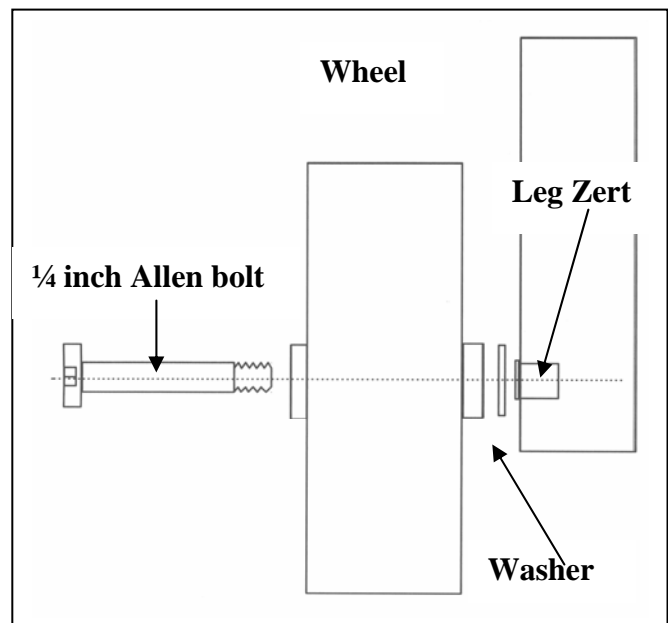

### ***Installing The Viper Casters:***

Use a second person to help lift up the barbecue body.  
Install casters as shown in the diagram.

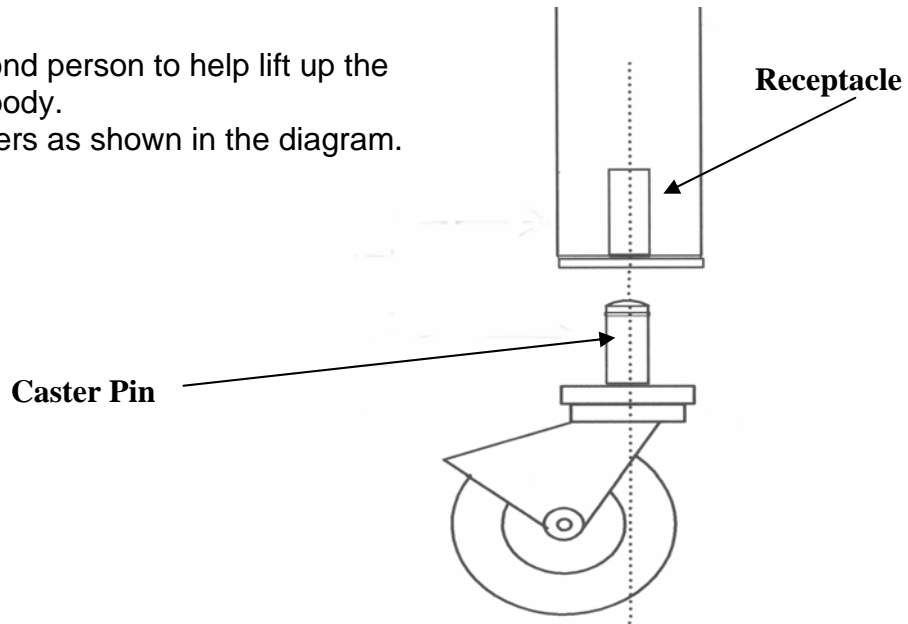

### **POSITIONING THE U-SHAPED FIREPOT COVER AND ANGLED DRIP PAN:**

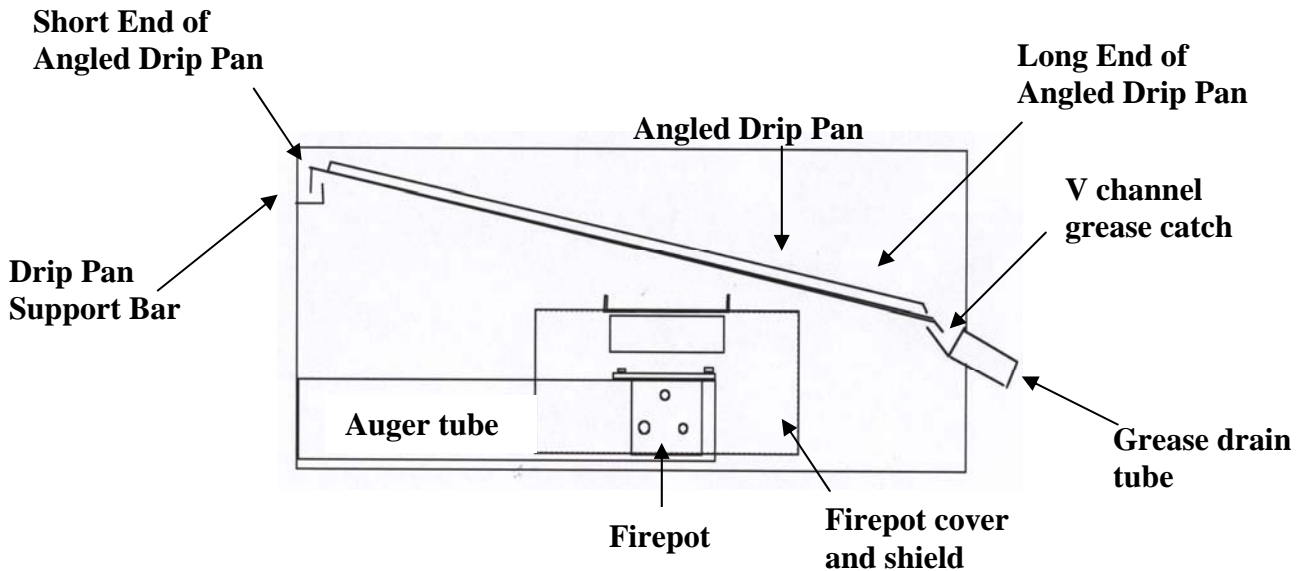

Become familiar with each of the components and how they fit inside your barbecue.

### **HANGING THE GREASE BUCKET**

Locate the grease drain tube (16) found at the bottom right hand side of the main barbecue body. Hang the grease bucket (22) on the hook on the drain tube (16).

## SECTION TWO: EMPTY PELLET HOPPER LIGHTING INSTRUCTIONS

*(To be used on initial firing or anytime the unit runs out of pellets)*

**In order to ensure proper operation of your grill, you must first allow the auger tube to be “charged” with pellets.**

1. Make sure the power switch is in the OFF position. Plug power cord into a 110 volt outlet.
2. Open the pellet hopper lid and locate the auger. Make sure there are no foreign objects in the auger. Turn the power on and look into the pellet hopper to confirm the auger is turning. At the same time, place your fingers over the firepot and feel the air movement from the combustion fan. Look and see if the hot rod is getting hot. **DO NOT TOUCH IT!** Turn the power switch off.
3. Fill the hopper with bbq pellets. Set the cook mode switch on HIGH (300 degrees on thermostat control). Note: During the initial charging of the auger, it will take approximately 5 minutes for the pellets to travel from the hopper to the firepot. When the pellets begin to fall into the firepot, Turn the power switch off. **WARNING! USE ONLY TRAEGER OR SMITH & WESSON BRAND BBQ PELLETS, which are specifically made to work in our grills. NEVER use heating fuel pellets in your unit.**
4. Turn the grill back on, set the cook mode switch on SMOKE. Let the pellets come to full flame. Once you see flames come out of the firepot, turn the power switch OFF and let the grill cool down. Line the angled drip pan with heavy-duty aluminum foil. Starting from the large end first, proceed in a right to left manner. Be sure that the foil that runs along the edge of the pan is tight against the bottom of the pan. Next, put the U-shaped firepot cover, angled drip pan and cooking grills back into their proper position. Set the cook mode switch or thermostat dial on SMOKE. Turn the power switch ON. In approximately 2 minutes you will notice whitish-gray smoke coming out of the grill. The hot rod will operate for four minutes before shutting off. After 4 minutes, the cook mode switch may be moved to any cooking setting you desire. **Note: Before cooking the first batch of food in your new grill, you will need to season the unit. Turn the cook mode switch to HIGH (300 degrees on thermostat control) and run for 45 minutes at this setting with the lid closed. This must be done before cooking food on your unit.**
5. After using the grill for the first time, it should take approximately 10 minutes of warm-up time before you can start cooking food inside the unit.

**ALWAYS START YOUR GRILL ON SMOKE MODE**

Once the pellets are ignited, you can switch to any cooking temperature you desire.

## **SECTION THREE: STANDARD LIGHTING PROCEDURE (For Normal Use)**

1. Set the cook mode switch or thermostat dial on SMOKE. Turn the power switch ON. In approximately 2 minutes you will notice whitish-gray smoke coming out of the grill. The hot rod will operate for four minutes before shutting off. After 4 minutes, the cook mode switch may be moved to any cooking setting you desire

## **SECTION FOUR: OPERATING TIPS**

- 1) Your Traeger Pellet Grill should never be moved while it is hot. If you are transporting your grill in a vehicle after cooking on it, make sure the fire is completely out and the unit is completely cold before placing it in any vehicle. NEVER put water in the firepot. It will jam the auger.
- 2) THE Traeger Pellet Grill is designed to operate with the LID CLOSED. Cooking with the lid open greatly lengthens your cooking time.
- 3) NEVER add pellets by hand to a hot firepot. This is dangerous and you may get seriously burned. If you run out of fuel and lose your fire while cooking, let the unit completely cool and start all over again with auto-start or manual lighting procedure.
- 4) Your Traeger comes equipped with a three position cooking mode control. The switch can be changed at any time to increase or decrease the temperature of your grill. "HIGH" is used for grilling. The auger runs all the time on "HIGH". The "MEDIUM" setting is for slow cooking. The auger will run for 2 minutes and then shuts off for 2 minutes. "SMOKE" is for smoking foods and adding wood smoked flavor to the foods you cook. The auger runs for 1 minute and is off for 3 minutes. This creates a natural wood smoke flavor to your food. The "SMOKE" setting can also be used to "hold" foods at approximately 180 degrees-200 degrees F.
- 5) After starting the grill, make sure the U-shaped firepot cover (5) is properly seated in its support brackets. The lips of the U-shaped firepot cover should be pointing down along the front and rear of the firepot. If not seated properly, direct heat and flame could come up out of the firepot and cause a grease fire in your grill.
- 6) When estimating cooking times, remember that the outside temperature will dramatically alter your cooking times. If it is hot outside, it will take less time for food to cook. If it is cold, wet or windy, it will take longer for food to cook.

- 7) Grease fires are caused by not properly maintaining your grill, or failing to clean your angled drip pan on a consistent basis. In the unlikely event you experience a grease fire while cooking, **keep the lid closed**. Never open the cooking chamber lid during a grease fire. If it does not go out, lightly sprinkle baking soda on the fire. Be careful not to burn yourself. If this does not work, then carefully remove the food from the unit (being careful not to burn yourself), turn the power switch off and shut the lid until the fire is completely out. When completely cool, remove the grill, replace the foil on the drip pan, reset the drip pan and cooking grill and resume cooking your food.

## **SECTION FIVE: MAINTAINING YOUR NEW GRILL**

1. Change the aluminum foil on the Angled drip pan after each use. Periodically clean the grease out of the V-channel grease catch, grease drain tube and interior surfaces of the barbecue. Empty the grease bucket when it is half-full. It's easier to clean off accumulated grease when the grill is warm. **BE CAREFUL NOT TO BURN YOURSELF**. If grease is allowed to build up too much on the angled drip pan in the V-channel grease catch, or is allowed to plug the grease drain tube, you could eventually get a grease fire. We recommend cleaning these locations after every 10 uses.
2. Outside surfaces. Do **NOT** use oven cleaner, abrasive cleansers or abrasive cleaning pads on the outside grill surfaces. Use warm soapy water to cut the grease.
3. If the grill is stored outdoors during the rainy season, care should be taken to insure that water does not get into the pellet hopper. Wood pellets, when wet, expand greatly and will jam your auger. Using **HYRDOTUFF** cover to protect your grill is highly recommended!
4. Two or three times a year, remove the cooking grill, angled drip pan and U-shaped firepot cover and clean in and around the firepot. A shop-vac is handy for this chore. Make sure the grill is **COMPLETELY COLD** before starting this procedure.
5. We recommend keeping a long-handled grill cleaning brush near the grill so that immediately after removing food from the grill, and while it is still warm, give it a quick brushing. It only takes a minute and the cooking grill will be ready the next time you want to cook on your grill. Be careful not to burn yourself!

**NOTE: When operating this barbecue, maintain a clearance of at least 10 inches from barbecue back to combustibles.**

## SECTION SIX: IF YOUR FIRE GOES OUT

If your grill fails to light or if the fire in the firepot goes out while cooking or smoking, follow these steps:

- 1) Turn off the unit. Open barbecue lid, remove all food, cooking grill, angled drip pan, and u-shaped firepot cover.
- 2) Remove ALL un-burnt barbecue pellets from inside and around the firepot.
- 3) **Before replacing the u-shaped firepot cover, angled drip pan and cooking grill**, restart your grill and confirm that the ignition cycle is working. (Hot rod should begin to turn red hot and pellets should fall into firepot from auger tube.
- 4) If this procedure is not successful refer to the ***Standard Lighting Procedure*** section in your owner's manual.

## SECTION SEVEN PARTS AND SERVICE

Part names are given in the front of this manual on the COMPONENT DIAGRAM PAGE. To order parts: Find the part name on the component diagram page. Call or write your Authorized Traeger dealer, distributor or Traeger Industries. Give us your name, phone number, address, model and serial number of your unit.

To order parts directly from the factory:

**TRAEGER PARTS DEPARTMENT**  
**PO Box 829**  
**Mt. Angel, OR. 97362**  
**(503) 845-9234**  
**TOLL-FREE: 1-800-872-3437**  
**Email : [service@traegergrills.com](mailto:service@traegergrills.com)**  
**Website: [www.traegergrills.com](http://www.traegergrills.com)**

